

Milton Site Electrical system Page 1 of 2

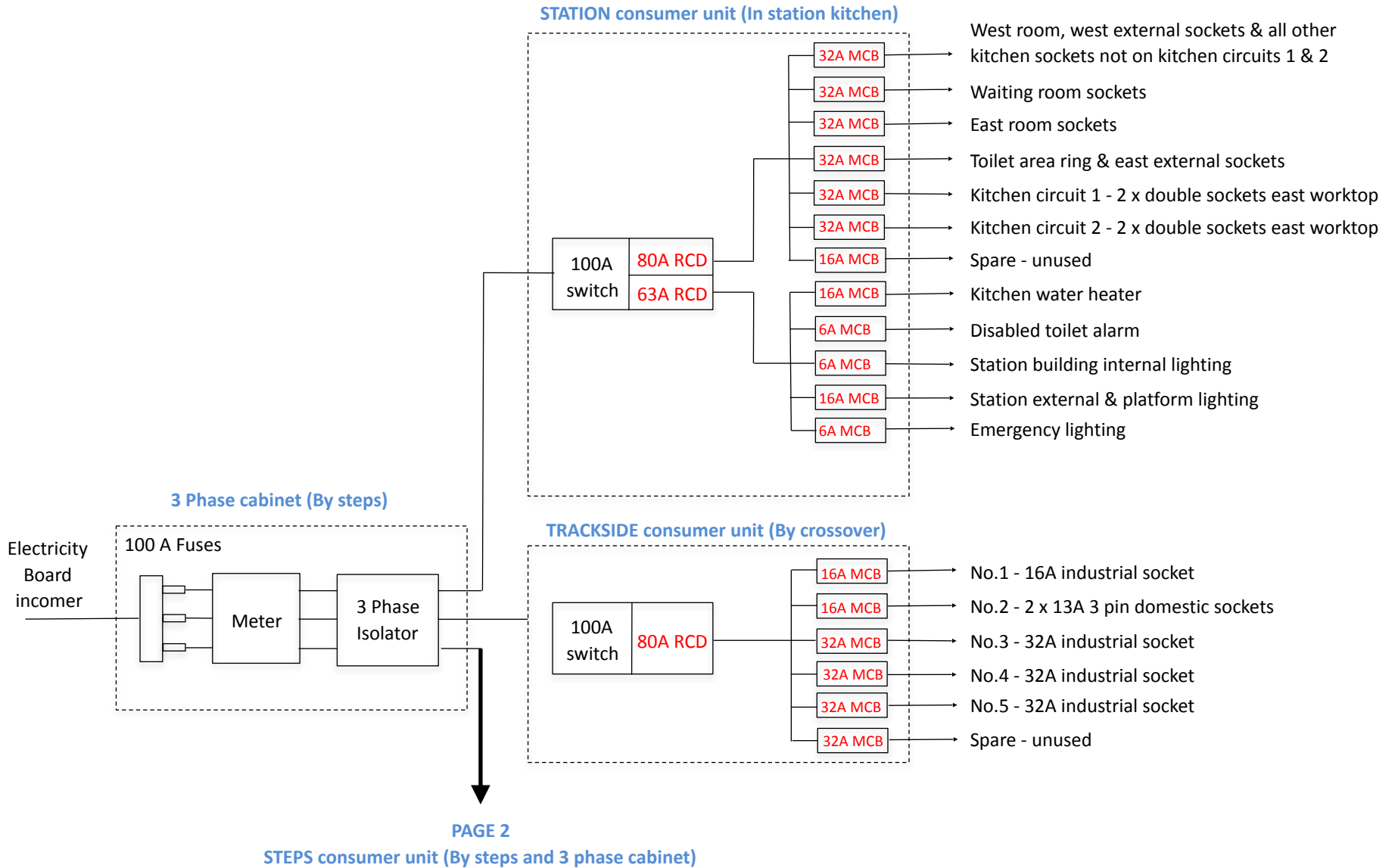

PAGE 2

STEPS consumer unit (By steps and 3 phase cabinet)

PAGE 1

